Operating instructions and Spare parts list

Gun control unit OptiStar 4.0 (CG21)



Translation of the original operating instructions

Documentation OptiStar 4.0 (CG21)

© Copyright 2018 Gema Switzerland GmbH

All rights reserved.

This publication is protected by copyright. Unauthorized copying is prohibited by law. No part of this publication may be reproduced, photocopied, translated, stored on a retrieval system or transmitted in any form or by any means for any purpose, neither as a whole nor partially, without the express written consent of Gema Switzerland GmbH.

Gema, EquiFlow, MagicCompact, MagicCylinder, OptiCenter, OptiFlex, OptiGun, OptiSelect and OptiStar are registered trademarks of Gema Switzerland GmbH.

ClassicLine, ClassicStandard, ClassicOpen, DVC (Digital Valve Control), GemaConnect, MagicControl, MagicPlus, MonoCyclone, MRS, MultiColor, MultiStar, OptiAir, OptiControl, OptiColor, OptiFeed, OptiFlow, OptiHopper, OptiMove, OptiSieve, OptiSpeeder, OptiSpray, PCC (Precise Charge Control), RobotGun, SIT (Smart Inline Technology) and SuperCorona are trademarks of Gema Switzerland GmbH.

All other product names are trademarks or registered trademarks of their respective holders.

Reference is made in this manual to different trademarks or registered trademarks. Such references do not mean that the manufacturers concerned approve of or are bound in any form by this manual. We have endeavored to retain the preferred spelling of the trademarks, and registered trademarks of the copyright holders.

To the best of our knowledge and belief, the information contained in this publication was correct and valid on the date of publication. Gema Switzerland GmbH makes no representations or warranties with respect to the contents or use of this publication, and reserves the right to revise this publication and make changes to its content without prior notice.

For the latest information about Gema products, visit www.gemapowdercoating.com.

For patent information, see www.gemapowdercoating.com/patents or www.gemapowdercoating.us/patents.

Printed in Switzerland

Gema Switzerland GmbH
Mövenstrasse 17
9015 St.Gallen
Switzerland

Phone: +41-71-313 83 00

Fax.: +41-71-313 83 83

E-mail: info@gema.eu.com

Technical Data

Connectable guns

OptiStar 4.0 (CG21)	connectable
OptiSelect Pro Type GM04	yes
OptiSelect Pro Type GM04-CF	yes**
OptiSelect type GM03	yes*
TriboJet	yes**



* The PowerBoost functionality is not available

** The gun type must be configured (refer to chapter "Typical properties – Characteristics of the functions").
The Tribo gun the gun is not type approved (ATEX).

WARNING

The gun control unit may only be used with the specified gun types!

Electrical data

OptiStar 4.0 (CG21)	
Nominal input voltage	100-240 VAC
Frequency	50-60 Hz
Fluctuations of the power supply	± 10 %
Overvoltage category	OVC II
Connected load	40 VA
Nominal output voltage (to the gun)	12 V
Nominal output current (to the gun)	1.2 A
Connection and output for vibrator (on Aux output)	110/230 VAC max. 100 W
Connection for rinsing function (valve)	24 VDC max. 3 W
Protection type	IP54
Approvals	 0102  II 3 (2) D PTB17 ATEX 5002

Pneumatic data

OptiStar 4.0 (CG21)	
Compressed air connection	8 mm
Max. input pressure	5.5 bar / 80 psi
Max. water vapor content of the compressed air	1.3 g/m ³
Max. oil vapor content of the compressed air	0.1 mg/m ³

Dimensions

OptiStar	
Width	173 mm
Depth	250 mm
Height	177 mm
Weight	approx. 2.6 kg

Powder output (reference values)

General conditions for the OptiFlow Injector

Powder type	Epoxy/polyester
Powder hose Ø (mm)	11
Type of powder hose	POE with guide strips
Input pressure (bar)	5.5
Correction value C0	Powder output zeroing adjustment

Guide values for OptiStar with OptiFlow Injector

All values in these tables are guide values for new nozzle inserts. Differing environmental conditions, wear and different powder types can affect the table values.

Hose internal diameter (mm)	Ø 11						
	6		12		18		
Hose length (m)							
Total air volume (Nm ³ /h)	3.5	5.5	3.5	5.5	3.5	5.5	
Powder output (g/min)							
Powder output (%)	20	90	105	65	75	45	60
	40	170	205	135	150	100	120
	60	235	280	185	215	145	170
	80	290	350	235	270	185	220
	100	340	405	280	320	220	260

Air flow rates

The total air consists of conveying air and supplementary air, in relation to the selected powder quantity (in %). As a result the total air volume is maintained constant.

OptiStar 4.0 (CG21)	Range	Factory setting
Flow rate – fluidizing air:		
– Device type B	0-1.0 Nm ³ /h	0.1 Nm ³ /h
– Device type F (without AirMover air requirements) / L	0-5.0 Nm ³ /h	1.0 Nm ³ /h
– Device type S (with optional fluid plate)	0-1.0 Nm ³ /h	0.1 Nm ³ /h
Electrode rinsing air flow rate	0-5.0 Nm ³ /h	0.1 Nm ³ /h
Flow rate total air (at 5.5 bar)	5 Nm ³ /h	
– Conveying air flow rate	0-5.5 Nm ³ /h	
– Supplementary air flow rate	0-5.5 Nm ³ /h	



The max. total air consumption during the coating operation is < 5,5 Nm³/h:

- Total air = 5 Nm³/h (conveying air + supplementary air)
- Electrode rinsing air = 0,1 Nm³/h (flat jet nozzle)



The total air consumption for the device is determined based on the 3 configured air values (without AirMover air value for device type F).

- These values apply for an internal control pressure of 5.5 bar!

Environmental conditions

OptiStar 4.0 (CG21)	
Utilization	in the interior
Height	up to 2 000 m
Temperature range	+5 °C - +40 °C (+41 °F - +104 °F)
Max. surface temperature	+85 °C (+185 °F)
Maximum relative humidity	80 % for temperatures to 31 °C, linearly decreasing to 50 % relative humidity at 40 °C
Environment	not for wet environment
Degree of pollution of the intended environment	2 (in accordance with DIN EN 61010-1)

Sound pressure level

OptiStar 4.0 (CG21)	
Normal operation	< 60 dB(A)

The sound pressure level was measured while the unit was in operation; measurements were taken at the most frequent operator positions and at a height of 1.7 m from the ground.

The specified value is applicable only for this product itself and does not take into account external noise sources or cleaning impulses.

The sound pressure level may vary, depending on the product configuration and space constraints.

Rating plate



fig. 2

Compatibility and interactions

The gun control unit is used for the following manual equipment from the OptiFlex line:

- OptiFlex B/Q (with powder box)
- OptiFlex F (with fluidized powder hopper)
- OptiFlex S (with stirrer container)
- OptiFlex C (with application cup)
- OptiFlex CF (with funnel cup)
- OptiFlex L (with lab device)
- OptiFlex W, K (Kits)
- OptiFlex Dual Gun Kit B, F
- OptiFlex Dual Gun Wall Kit B, F

Design and function

Overall view



Fig. 3

- | | | | |
|---|---|---|----------------------------|
| 1 | Front plate with control and display elements | 3 | Back panel with interfaces |
| 2 | Enclosure | | |

Operating elements

Displays



The desired and actual values are distributed across several levels.

- The  key is used to switch between the levels.
- If no controls are used within 6 s, the device automatically returns to level 1.

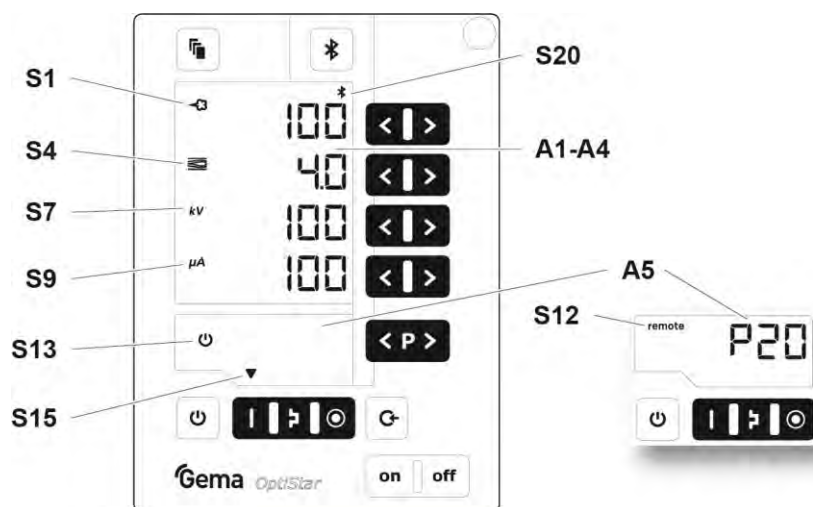

fig. 4: Displays, Level 1

Designation	Function
A1-A4	Display of actual values, desired values and system parameters <ul style="list-style-type: none"> - Flashes if the possible range is exceeded.
A5	Display of program numbers, error diagnosis codes and status information
S1	Powder output (display in %)
S4	Total air volume (display in Nm ³ /h)
S7	High voltage (display in kV)
S9	Spraying current (display in µA)
S12 remote	Remote operation mode, no local operation possible <ul style="list-style-type: none"> - Remote operation mode is used as keyboard lock, reduced operation is possible
S13	Activation of vibration/fluidization
S15	Display of predefined operating modes or display of cleaning mode during cleaning
S20	<ul style="list-style-type: none"> - Display of readiness for pairing the Bluetooth module with a mobile device (green) - Display of an active connection (blue)

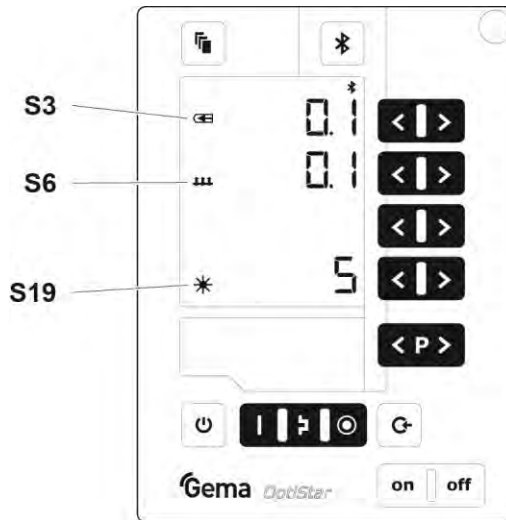

fig. 5: Displays and LEDs, Level 2

Designation	Function
S3	Electrode rinsing air* (display in Nm ³ /h)
S6	Fluidizing* (display in Nm ³ /h)
S19	Display background illumination (0-8)

* The value for this function cannot be set for the OptiSelect Pro GM04-CF gun type.

Input keys and switches

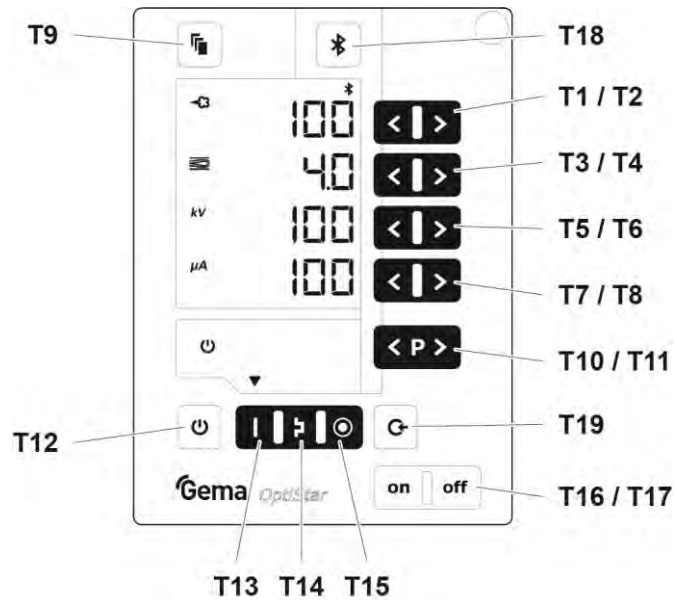

fig. 6: Input keys and switches





Designation	Function
T1-T8	Input keys for desired values and system parameters
T9	Switch between display levels
T10-T11	Program change
T12	<ul style="list-style-type: none"> – Switching on and off the fluidization (equipment type F) – Switch on/off for vibration and fluidization (equipment type B) – Switching on and off the stirrer (equipment type S) – Switchover to system parameter mode (press for at least 5 secs.)
T13	Preset mode for flat parts (fixed values)
T14	Preset mode for complex parts with depressions (fixed values)
T15	Preset mode for overcoating parts already coated (fixed values)
T16/T17	Power switch On/Off
T18	<ul style="list-style-type: none"> – Activation of the pairing readiness from the Bluetooth module to the mobile device (press for at least 2 seconds) – Display of the ID number (press for a short time)
T19	<ul style="list-style-type: none"> – Switching on the rinsing mode (PowerClean) with optional PowerClean module – Terminating the rinsing mode (PowerClean) with optional PowerClean module

Connections

Compressed air hoses / cables



fig. 7: Connections

Connection	Description
1.1 Main air IN	Compressed air connection
2.1 Power IN	Mains cable connection
2.2 Aux	Vibration motor connection for equipment type B
2.3 Gun	Gun cable connection
2.4 Power Clean	Connection to rinsing module
1.2 	Conveying air connection
1.3 	Supplementary air connection
1.4 	Electrode rinsing air connection
1.5 	Fluid air connection
	Grounding connection

Pin assignment

Power IN



2.1

Power IN connection

- 1 Neutral conductor (power supply)
- 2 Phase (100-240 VAC)
- 3 Output vibrator or stirrer
- PE PE grounding

Aux



2.2

Aux Connection

- 1 Neutral conductor
- 2 Output vibrator, phase
- 3 Not used
- PE PE grounding

Gun



2.3

Gun connection

- 1 Ground
- 2 Remote control 1 (GM03)
- 3 Ground
- 4 Trigger
- 5 Remote control 2 (GM03)
- 6 Oscillator
- 7 PE grounding

PowerClean Connection



2.4

- 1 Ground
- 2 +24 VDC
- 3 Not used
- PE PE grounding

Scope of delivery

- Power cable (country-specific)
- Quick-start guide and operating manual

Typical properties – Characteristics of the functions

Operating modes

The gun control unit has two operating modes.

Predefined operating mode (Preset mode)

The gun control unit has three preset application modes:

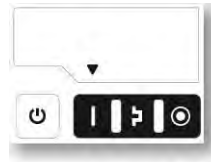

Fig. 8



Application mode for flat parts

This application mode is suitable for the coating of simple, flat workpieces without larger cavities.



Application mode for complicated parts

This application mode is suitable for the coating of three-dimensional workpieces with complex shapes (e.g. profiles).



Application mode for recoating parts already coated

This application mode is suitable for the overcoating of workpieces which are already coated.

In this operating modes, current (μA) and high voltage (kV) are preset, while powder and air volumes can be set and stored for each application mode.

Adjustable operating mode (Program mode)

In this operating mode, 20 individually definable programs (P01-P20) are available. These programs are automatically saved and can be recalled again as the application requires.



fig. 9

The values for current, high voltage, powder output, total air and electrode rinsing air can be set as needed for a given application.



The settings defined in the 20 programs and 3 application modes are automatically stored, without confirmation!

Precise Control of spraying Current (PCC Mode)

For coating components with both complex and simple geometries, a spraying current of below 10 μA can be selected to prevent unintended overcoating on the simpler surfaces. This is especially important in combination with high loading powders (such as metallic). The controller automatically switches into "PCC mode". This allows for very fast yet highly precise control. The high voltage and spray current values and their symbols are depicted in red:



Fig. 10: PCC mode

Maximum coating performance (PowerBoost Mode)

For maximum coating performance, both the spray voltage and the spray current can be set to a fixed value of 110 kV / 110 μA . This functionality is particularly suitable for coating large-surface components with both simple and complex geometries in combination with high powder output.

The control unit automatically switches to PowerBoost mode when the spray voltage value above 100 kV is selected.

The high voltage and spray current values and their symbols are depicted in red:



fig. 11: PowerBoost Mode





Communication with the Gema electrostatic app

The control unit is prepared for communication* with the Gema electrostatic app.



The electrostatic app is optimized for mobile devices with a screen diagonal up to 15 cm (6").

The app enables customers to improve their productivity by providing the following areas:

 <p>Application</p>	<p>All important application parameters are clearly displayed on the mobile device and can be adapted immediately.</p>
 <p>Line management</p>	<p>The coating productivity data can be retrieved at any time. Statistics and cost estimates of the order are generated automatically. Maintenance can be scheduled.</p>
 <p>Setup</p>	<p>This configures the OptiStar control unit. The OptiStar can be controlled individually or as a participant in a group. System information and diagnostic data can easily be retrieved and sent as e-mail.</p>
 <p>Service</p>	<p>Enables direct access to the operating instructions of the system components and to the Gema website.</p>

The secure connection between the control unit and the device can be established very easily with the help of the  key.

The prerequisite for this is that every control unit in the system already has its own Bluetooth ID number. See chapter "System parameter P11 (Bluetooth ID no.)" on page 37.

A description of the app can be found in a separate manual.

* Disabled in network operation

Rinsing mode

The PowerClean mode is used to blow powder accumulations and moisture out of the powder hose, injector, and gun using compressed air.

The device provides three rinsing modes:

Rinsing mode	PowerClean™ module (Option)	Compressed air volume flow
simple rinsing mode	without	approx. 10 Nm³/h
PowerClean™ Mode	with	approx. 25 Nm³/h
PowerClean™ Mode (for equipment type Q)	with	approx. 25 Nm³/h

The desired rinsing mode must be set in the system parameter P01 (see "Entering the system parameters").



The rinsing mode can only be activated from standby mode, namely by pressing the P key on the gun remote control or the



key on the gun control unit.

- See chapter "Rinsing mode" on page 47.

The rinsing mode is signaled by a circling LCD segment on the display:

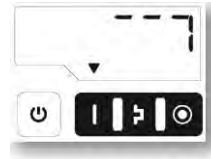

fig. 12: Rinsing mode active

The rinsing procedure is stopped by pressing the gun trigger.

Once the cleaning mode is quit, the unit automatically returns to the last program.

Remote control by gun

Various functions can be remotely controlled using the buttons on the rear side of the powder gun (OptiSelect Pro GM04 gun type).



The respective option is set in the OptiStar control unit in accordance with system parameter P12.

- 0**
 - Modify the powder output (press the **A** or **V** key on the gun. The powder output will be increased or decreased accordingly)
 - Switch to PowerClean mode (Press **P** button)

or

-
- 1
 - Change programs (press the **Λ** or **V** key on the gun. It is switching between programs P01-P20. To be able to use this function, it must first be activated.
 - Switch to PowerClean mode (Press **P** button)
-

or

- 2
 - Modify the powder output (press the **Λ** or **V** key on the gun. The powder output will be increased or decreased accordingly)
 - direct temporary activation of the PowerBoost function (press **P** key)
-



The remote control is blocked as long as the keyboard lock is activated or while in system parameterization mode.



Pressing one of the keys calls up the desired values instead of the actual values!

Keyboard lock

The gun control unit has a keyboard lock to prevent modification of individual parameter values (kV, μ A etc.) within the operating modes (Program and Preset). Following is not affected by the keyboard lock:

- Program selection
- Display of the desired values of the current program
- Display of the actual values
- Error acknowledgment

An active keyboard lock is indicated by a blinking of the **remote** display. To be able to use this function, it must first be activated. See chapter "Activate/deactivate the keyboard lock" on page 50.



fig. 13

The keyboard lock status remains stored, when switching the equipment off and on. The keyboard lock is cancelled if a RAM reset is performed.

Background illumination

Brightness

8 different brightness settings are available for the display. The setting remains in place when the machine is switched on/off.

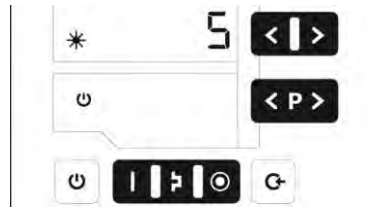

Fig. 14

Auto Power Save mode

If no powder is being applied, then the background lighting turns off automatically 5 minutes after a button has been pressed last time.

Correction values

The Gun control unit can be adapted with the correction values optimally to local conditions (e.g. the adjustment of different powder outputs in the plant).

See chapter "Setting correction factor for powder output" on page 45.

Operation and configuration of the cup gun

The cup gun type OptiSelect Pro GM04-CF can be connected to the manual gun control unit. The gun control must first be set to this gun type in system parameter **P00** before start-up.

See chapter "System parameters" on page 31.

Operation and configuration of the Tribo gun

The Tribo gun can be connected to the manual gun control unit. The Tribo gun can be configured by holding the keys **T5** and **T6** when switching on. The selected adjustment remains stored, when the device is switched off. The settings are also retained if the device type is changed. The Tribo gun mode can also be deactivated using the procedure mentioned above.

The charging current (μA) is displayed in the main menu during coating process:

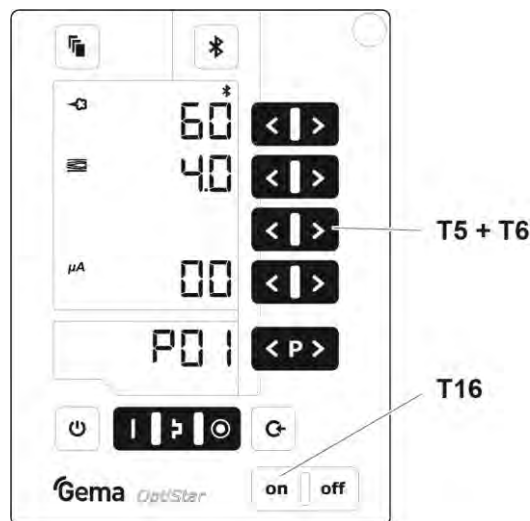

fig. 15:

Assembly / Connection

Assembly guide

The gun control unit is mounted into place using 2xM6 screws on the front side. Please contact Gema for other installation possibilities.



Fig. 16

Connection instructions

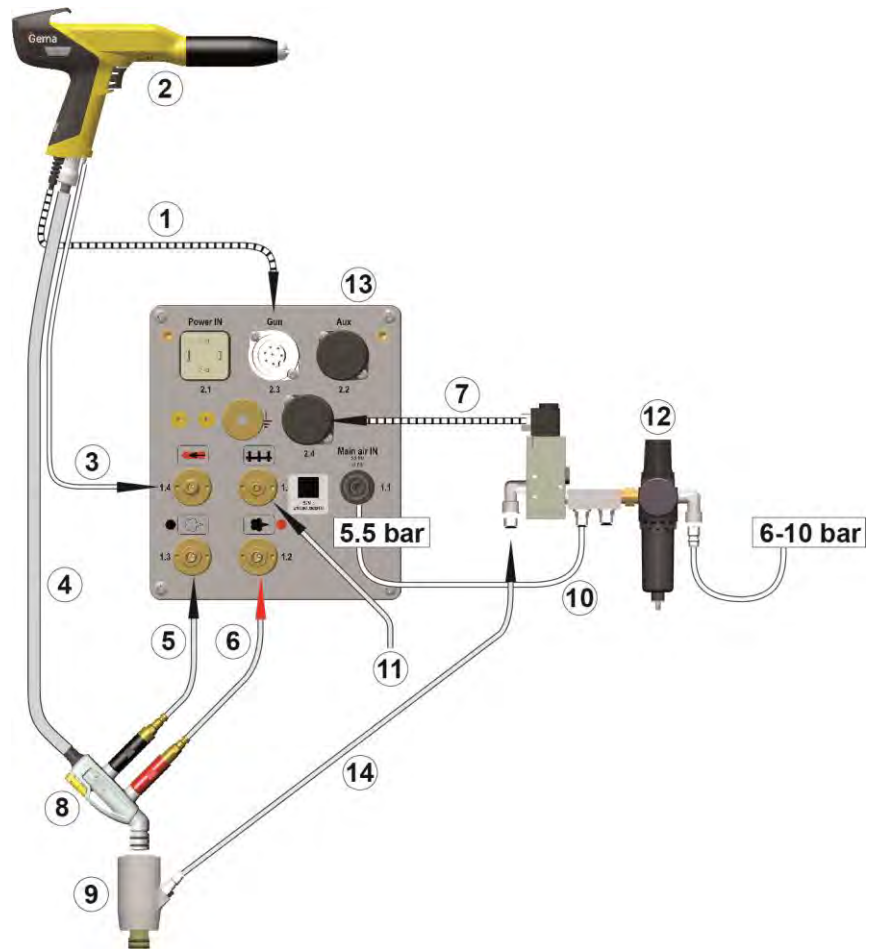

fig. 17: Connecting guide – overview

- | | |
|------------------------------|-------------------------------|
| 1 Gun cable | 8 Injector |
| 2 Manual gun | 9 PowerClean™ module (Option) |
| 3 Electrode rinsing air hose | 10 Compressed air hose |
| 4 Powder hose | 11 Fluidizing air hose |
| 5 Supplementary air hose | 12 Maintenance unit |
| 6 Conveying air hose | 13 OptiStar Control unit |
| 7 Control signal cable | 14 Rinsing air hose |



Use clamp to connect grounding cable to the cabin or the suspension arrangement.

- Check ground connections with Ohm meter and ensure 1 MOhm or less.



The compressed air must be free of oil and water!



Close the unused connections with the provided dust protection caps!

Start-up

Preparation for start-up



The gun control unit always starts up to the last configured settings.

Basic conditions

When starting up the gun control unit, the following general conditions impacting the coating results must be taken into consideration:

- Gun control unit correctly connected
- Gun correctly connected
- Corresponding power and compressed air supply available
- Powder preparation and powder quality

System parameters

The Gun control unit is configured by using the system parameters. This configuration will be saved in the equipment memory.

Entering the system parameters

1. Turn on the gun control unit with the **ON** key
2. Hold  key down for 5 seconds
 - The display switches to the following level:

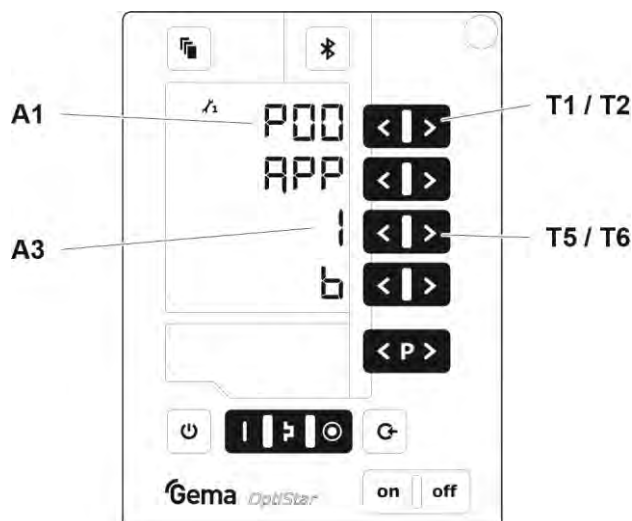

3. The system parameter number is shown in the display **A1** with a **P** placed in front
4. Set the corresponding system parameter value with the **T5** or **T6** key.
 - The value of the adjusted system parameter appears on corresponding display **A3**
5. Scroll to the next or previous system parameter with the **T1** or **T2** key



Selection is cyclical, i.e. after the last system parameter, the first starts again and vice versa.

6. Select parameter values according to the following table

No.	Description	Values	Display
P00¹⁾	Device type	0: Fluidizing device type F (CG21)	F
		1: Box device with vibrator Type B (CG21)	B
		2: Stirrer device Type S (CG21)	S
		3: Automatic device (CG20/CG20-C)	A
		4: Stirrer device with fluidization (CG21)	S Fd
		5: Application pump (CG23-P)	P
		6: Application pump + CAN bus (CG24-CP)	CP
		7: Cup gun unit Type CF with GM04-CF gun (CG21)	PCF

No.	Description	Values	Display
P01	Rinsing mode	0: no PowerClean module present 1: PowerClean module present 2: PowerClean module present (equipment type Q)	
P03	Unit of measurement (air)	0: Nm³/h 1: scfm	nn3 scf
P07	Air volume setting	0: Standard (PA / GL) 1: Advanced (FL / ZL)	Std Adv
P10	Log level	0, 1, 2 , 3, 4, 5	LoG
P11	Bluetooth ID no.	0: Bluetooth deactivated 1 - 255	blid
P12	Remote Manual Gun	0: Powder output +/- PowerClean (Activation) 1 : Program change PowerClean (Activation) 2: Powder output +/- PowerBoost (Activation)	PAC PrC PAb

¹⁾ is not overwritten, if a Memory Reset is performed
 Default values are marked by **bold** print.

7. Press  key to quit the system parameter mode.
 The display switches to the standard level

System parameter P00 (device type)



If the control unit is supplied as a component of a manual coating unit, then the corresponding system parameter is set correctly by the factory!

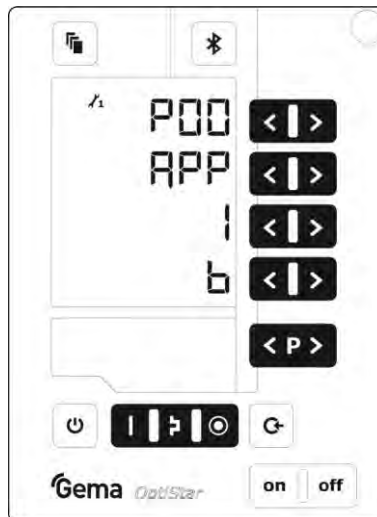

fig. 18: System parameter P00

WARNING

A wrong parameterization leads to various malfunctions!

- ▶ The system parameter P00 must be set to 0, 1, 2, 4 or 7!

Manual devices are subdivided into fluidizing, box or stirrer types. These sub-types differ in the control of the vibrator output and the behavior of the fluidizing air.

Device type	Function AUX Output	Fluidizing air function
Fluidizing device (type F)	Always Off	The gun trigger switches the fluidization on. The T12 key turns the fluidization On and Off .
Box device (type B)	Vibration On during triggering, wake for 30 seconds	Fluidizing air switches on parallel to the main solenoid valve (trigger).
	The T12 key turns the vibration On and Off	The T12 key turns the fluidization On and Off .
Stirrer device (type S)	Stirrer On during triggering	

Device type	Function AUX Output	Fluidizing air function
Stirrer device with fluidization (type S Fd)	Stirrer On during triggering	Fluidizing air switched On and Off with trigger. The T12 key also activates or deactivates the fluidization.
Cup gun device (type CF)	Always Off	Fluidizing air always switched off

System parameter P01 (rinsing mode)

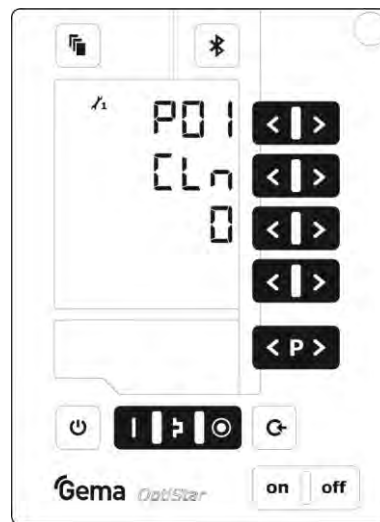





fig. 19: System parameter P01

See chapter "Rinsing mode" on page 47.

P01 parameter value	Description
0	 Manual equipment without PowerClean module
1	 Manual equipment with PowerClean module
2	 Type Q Manual coating equipment with PowerClean module

System parameter P03 (measuring unit)

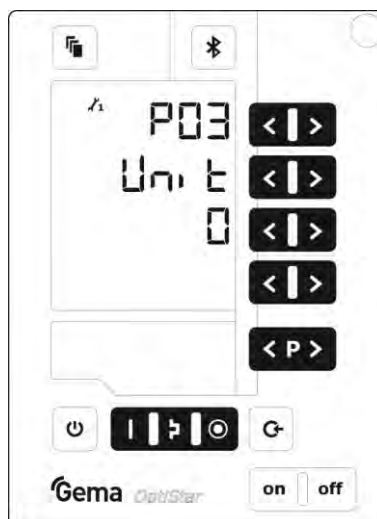

fig. 20: System parameter P03

This parameter is used to determine the measuring unit for all airs (total air and electrode rinsing air). If the parameter is set to **1 (scfm)**, then all air values are shown in this measuring unit. These lines are displayed in **blue**.

System parameter P10

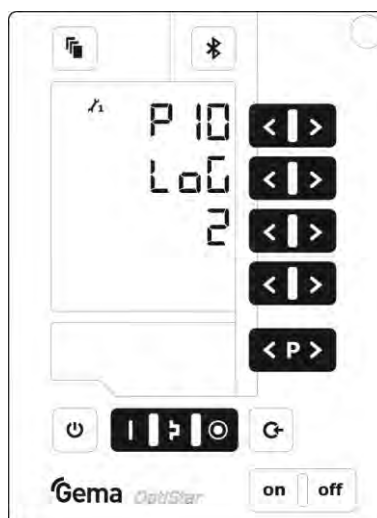

fig. 21: System parameter P10

The device can export log reports of the program run to an SD card for test purposes and for finding defects.

If an SD card is inserted during the switching on procedure, the log messages are also recorded onto the SD card. The data are record in the MESSAGES.LOG file in the root directory. Once this file reaches a size of 32 MB, it is renamed as MESSAGES.1 and a new MESSAGES.LOG file is then created.

Parameter value	Level of detail of reports
0	no messages
1	few details
...	
5	all messages



Real time timings can be impaired from a level of detail of 4.

System parameter P11 (Bluetooth ID no.)

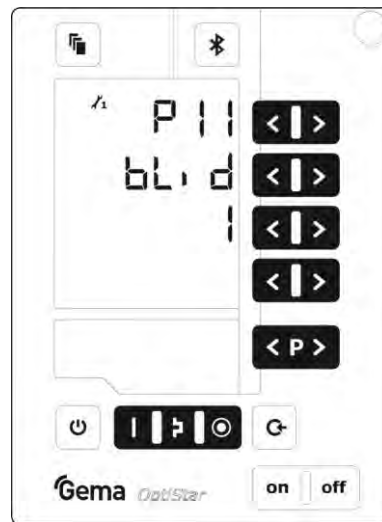

fig. 22: System parameter P11

The Bluetooth ID number is determined with this parameter. An individual Bluetooth ID number must be assigned to each pistol control unit that is to be accessed via the Gema electrostatic app.

System parameter P12 (Remote Manual Gun)

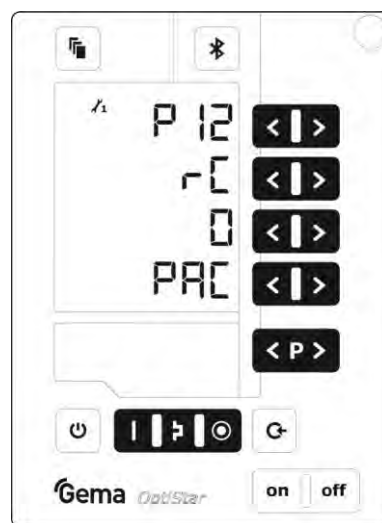







fig. 23: System parameter P12



P12 parameter value	Description	
0		Change the powder output +/-
		Activating/Deactivating the rinse mode
1		Program change +/-
		Activating/Deactivating the rinse mode
2*		Change the powder output +/-
		Activation of the PowerBoost function

* **ATTENTION:**
 This value must not be selected when operating devices type "Q Dual Gun"!



Pairing of the Bluetooth module with a mobile device

The first connection setup in which Bluetooth devices are coupled is also called pairing.

Following conditions have to prevail:

- the E app has already been downloaded and installed from an app distribution platform ( or ) (Keyword "**gema e-app**").
- ID number set in system parameter P11.
- Bluetooth activated on mobile device

To use Gema's E-app, proceed as follows:

1. Start the E-app
2. Keep the  key on the control unit pressed for two seconds
3. Press 
4. Select OptiStar
 - the control unit is now paired. The communication partners exchange key data so that they automatically recognize each other next time.

More information on how to use Gema's E-app can be found in a separate manual.

Operation

Operation





During the initial commissioning of the device, the functional check is to be performed without powder!

Select predefined operating mode (Preset mode)

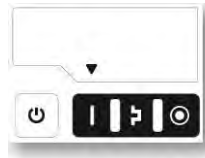
1. Turn on the gun control unit with the **ON** key
2. Press the corresponding application key.
The arrow above the desired button lights up.



The pre-defined application modes have preset values for high voltage and spray current:

Application mode		Preset kV	Preset μ A
	flat parts	100	100
	complicated parts	100	22
	overcoat	100	10

3. The air values for total air, powder output and electrode rinsing air can be individually defined and are saved in the programs.

Starting the individual adjustable programs

1. Turn on the gun control unit with the **ON** key
2. Press the **< P >** program key
3. Select the desired program (01-20)



Program 20 active

4. Change the coating parameters as required



Programs 01-20 are preset at the factory but can be modified at any time, after which they are automatically stored.

Description		Presetting
	Powder output	60 %
	Total air	4.0 Nm ³ /h
	High voltage	80 kV
	Spray current	20 μA
	Electrode rinsing air	0.1 Nm ³ /h
	Fluidizing air	1.0 Nm ³ /h (for device type F) 0.1 Nm ³ /h (for device type B and S)

Setting powder output and powder cloud

The powder output depends on the selected powder output (in %), and the powder cloud on the selected total air volume.



As a factory default value, a powder rate of 50% and a total air volume of 4 Nm³/h are recommended.

- If values are entered that the gun control unit cannot implement, then the operator is informed of this by a blinking in the relevant display and a temporary error message!

Setting the total air volume



1. Adjust the total air volume on the gun control unit with the **T3/T4** keys

- Adjust the total air volume according to the corresponding coating requests

Rinsing mode

The rinsing mode enables blowing off powder accumulations in the powder hose.

Activating the rinsing function

Manual equipment without optional PowerClean module (system parameter P01=0)

The rinsing mode can only be activated from standby mode (main menu display, no powder conveying).



On manual coating equipment type F, the injector must be disconnected prior to cleaning procedure, on type B, the suction unit must be lifted, and on type S, the powder container must be empty.

1. Detach the injector



- 2.

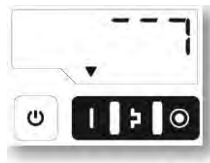

3. **START =**



1 x

= Automatic Procedure



2 x

= Manual Procedure



Procedure	Effect
Automatic (automatic)	<ul style="list-style-type: none"> - The rinsing process is started - Injector, powder hose, gun and spray nozzle are purged using compressed air - The PowerClean function enables parallel cleaning of other components, such as the fluid intake unit, powder container, etc. - The rinsing mode is exited if the automatic rinsing sequence has finished.
Manual (manual)	The operator controls the number and length of the PowerClean impulse by pressing the gun trigger a second time

4. **STOP =**



OR

OR the cleaning mode is terminated automatically.

After completion of the PowerClean procedure, the controller switches back to coating mode.

Manual equipment with optional PowerClean module (system parameter P01= 1 or P01=2)

The rinsing mode can only be activated from standby mode (main menu display, no powder conveying).



2. **START =**



Procedure	Effect
Automatic (automatic)	<ul style="list-style-type: none"> – The rinsing process is started – Injector, powder hose, gun and spray nozzle are purged using compressed air – The PowerClean function enables parallel cleaning of other components, such as the fluid intake unit, powder container, etc. – The rinsing mode is exited if the automatic rinsing sequence has finished.
Manual (manual)	The operator controls the number and length of the PowerClean impulse by pressing the gun trigger a second time

3. STOP =



OR the cleaning mode is terminated automatically.

After completion of the PowerClean procedure, the controller switches back to coating mode.

Setting the background illumination

1. Press the  key

The display switches to the following level:

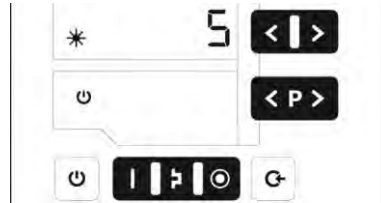

2.  * 5 <I>

Select the desired brightness

Activate/deactivate the keyboard lock

1. Hold  key pressed
2. Press the corresponding key:

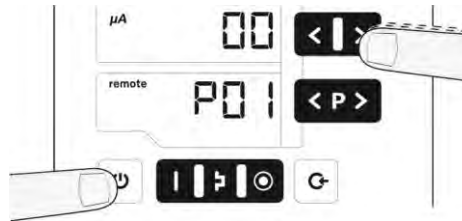

- The keyboard lock will be activated. The **remote** display blinks.
3. The keyboard lock is cancelled by pressing the same key combination

Checking the software version

1. Press these two keys at the same time

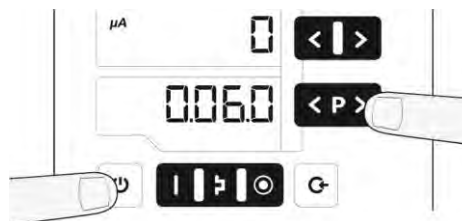

- The status display is shown as long as the keys are held.

Checking the trigger time

1. Press these two keys at the same time

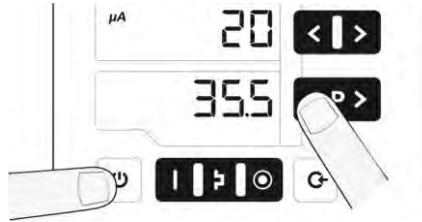

- The trigger counter (total time in days of trigger time) is shown in the display (e.g. 35.5 days = 852 h).

The status display is shown as long as the keys are held.



The trigger counter can't be reset!

RAM Reset

The RAM reset enables a restore of factory settings of the gun control unit. All parameters (**except P00**) and correction values as well as all user-defined values in the Program mode and Preset mode will be overwritten with factory default values. An active keyboard lock will be deactivated.



By resetting the RAM, all user-made settings will be set to factory default!

1. Switch off the device
2. Press the  key and hold it
3. Switch on the control unit, the **CLR** display blinks



4. Wait for approximately 5 seconds until **CLR** disappears
5. Release the  key
 - All values are reset. The control unit must be set-up again.

Decommissioning / Storage

Shutdown

1. End the coating procedure
2. Switch off the control unit



The adjustments for high voltage, powder output volume and electrode rinsing air remain stored.

If in disuse for several days

1. Switch off the plant with the main switch
2. Clean the gun and the components for powder conveying (see therefore the corresponding user manuals)
3. Turn off the compressed air main supply

Storage conditions

Hazard notes

There is no danger to personnel or the environment if the unit is stored properly.

Type of storage

For safety reasons, the product should only be stored in a horizontal position

Storage duration

If the physical conditions are maintained, the unit can be stored indefinitely.

Space requirements

The space requirements correspond to the size of the product.

There are no special requirements concerning distance to neighboring equipment.

Physical requirements

Storage must be inside a dry building at a temperature between +5 and +50 °C. Do not expose to direct sunlight!

Maintenance during storage

Maintenance schedule

No maintenance schedule is necessary.

Maintenance works

During long-term storage, periodically perform a visual check.

Maintenance / Repairs

General information

The product was designed for a maintenance-free operation.

Periodic checks

The periodic checks include examining all connecting cables and hoses.

The corresponding parts should be replaced immediately if any damage to cables or hoses is discovered.

All plugs must be properly tightened.

Repair work

In the event of malfunctions or faults, the product must be checked and repaired by an authorized Gema service workshop. The repairs must only be performed by an authorized specialist.

Improper tampering can result in serious danger for user and equipment.

Fault clearance

Error diagnosis of the software

General information

The correct function of the Gun control unit is constantly monitored. If the equipment software determines a fault, an error message is indicated with a help code. Following is monitored:

- High voltage technology
- Pneumatic system
- Power supply

Help codes

The error diagnosis codes (help codes) are shown in red on the **A5** display.

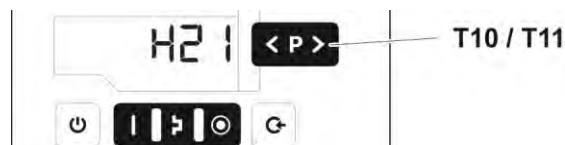

The help codes are stored in an error list in the order of their appearance. Each error in the list must be individually acknowledged with the keys **T10** or **T11**.

The errors are displayed in the order of their appearance. The **T10** and **T11** keys cannot be used for other functions, as long as an error code is still shown.

Here is a list of all possible help codes for this Gun control unit:

Code	Description	Criteria	Remedy
Pneumatics:			
H05	PowerClean valve	<ul style="list-style-type: none"> – PowerClean valve not connected – Valve defective – Connection cable defective – Mainboard defective 	<p>connect or replace</p> <p>Contact a Gema service center</p>

Code	Description	Criteria	Remedy
H06	Trigger valve	Solenoid coil current lower than preset limiting value Valve defective, main board or cable defective	Contact a Gema service center
H07	Supplementary air volume too high (setting of supplementary air on the display)	The preset value for supplementary air is too high compared to the conveying air setting	Lower supplementary air value or increase value for conveying air to equalize air volumes to the injector, delete error code
H08	Conveying air volume too high (setting of powder share on the display)	The preset value for conveying air is too high compared to the supplementary air setting	Lower conveying air value or increase value for supplementary air to equalize air volumes to the injector, delete error code
H09	Powder output higher than 100%	The powder output multiplied by the powder hose length factor and daily correction value is greater than 100% Daily correction value too large	Reduce powder output Reduce daily correction value
H10	Conveying air range lower deviation	The theoretical value for conveying air falls below minimum Total air is smaller than minimum	Limit conveying air to its minimum value

High voltage:

H11	Gun error	No vibrations in the oscillator, cable break, oscillator or gun is defective	Contact a Gema service center
H13	Gun Overload	Cable or cascade defective. The control unit is switched off.	Contact a Gema service center

Power supply:

H20	Voltage supply error Mainboard	Mainboard defective	Contact a Gema service center
H21	Supply undervoltage	Power pack defective or overloaded	Contact a Gema service center
H22	Wrong internal system clock	Backup battery is empty	Contact a Gema service center

EEPROM (equipment memory):

H24	EEPROM content invalid	EEPROM error	Contact a Gema service center
H25	Timeout during EEPROM writing	EEPROM error	Contact a Gema service center
H26	Values not correctly stored in EEPROM during switching off	EEPROM error	Contact a Gema service center
H27	EEPROM verification erroneous	EEPROM error	Contact a Gema service center

Throttle motors:

H60	Conveying air reference position not found	Throttle motor or needle jammed, limit switch defective, error in motor throttle	Contact a Gema service center
-----	--	--	-------------------------------

Code	Description	Criteria	Remedy
H61	Supplementary air reference position not found	Throttle motor or needle jammed, limit switch defective, error in motor throttle	Contact a Gema service center
H62	Electrode rinsing air reference position not found	Throttle motor or needle jammed, limit switch defective, error in motor throttle	Contact a Gema service center
H63	Fluidizing air reference position not found	Throttle motor or needle jammed, limit switch defective, error in motor throttle	Contact a Gema service center
H64	Conveying air throttle does not move	Short circuit in limit switch, motor throttle defective	Contact a Gema service center
H65	Supplementary air throttle does not move	Short circuit in limit switch, motor throttle defective	Contact a Gema service center
H66	Electrode rinsing air throttle does not move	Short circuit in limit switch, motor throttle defective	Contact a Gema service center
H67	Fluidizing air throttle does not move	Short circuit in limit switch, motor throttle defective	Contact a Gema service center
H68	Conveying air position lost	Lost steps, limit switch defective, throttle motor defective	Contact a Gema service center
H69	Supplementary air position lost	Lost steps, limit switch defective, throttle motor defective	Contact a Gema service center
H70	Electrode rinsing air position lost	Lost steps, limit switch defective, throttle motor defective	Contact a Gema service center
H71	Fluidizing air position lost	Lost steps, limit switch defective, throttle motor defective	Contact a Gema service center
Communication mainboard-gun:			
H91	Communication error mainboard-gun	Gun not connected Gun, gun cable or Mainboard defective	connect Replace or contact Gema Service

Help codes list

The last appeared four errors are stored in a list by the software. If an error appears, which is already in the list, he will not be listed again.

Appearance of errors

It is possible that an error is only displayed for a short time, but after the acknowledgement it will disappear. In this case, it's recommended to switch off the control unit and switch it on again (reset by restarting).

Disposal

Introduction

Requirements on personnel carrying out the work

The disposal of the product is to be carried out by the owner or operator. When disposing of components that are not manufactured by Gema, the instructions in the respective manufacturer's documentation must be observed.

Disposal regulations



The product must be disassembled and disposed of properly at the end of its service life.

- ▶ When disposing of the product, the applicable local and regional laws, directives and environmental regulations must be complied with!
-

Materials

The materials must be sorted according to material groups and taken to the appropriate collection points.

Disassembly of component groups

WARNING

Live components

Risk of fatal injury from electric shock if touched

- ▶ Only trained, authorized staff may open the electrical compartment
 - ▶ Observe the safety symbols
-

1. Disconnect the mains supply and supply cables.
2. Remove all product covers.

The product is now prepared for disassembly.

Spare parts list

Ordering spare parts

When ordering spare parts for powder coating equipment, please indicate the following specifications:

- Type and serial number of your powder coating equipment
- Order number, quantity and description *of* each spare part

Example:

- **Type** OptiGun GA03 automatic powder gun
Serial number 1234 5678
- **Order no.** 203 386, 1 piece, Clamp – Ø 18/15 mm

When ordering cable or hose material, the required length must also be given. The spare part numbers of this bulk stock is always marked with an *.

Wearing parts are always marked with a #.

All dimensions of plastic hoses are specified with the external and internal diameter:

Example:

Ø 8/6 mm, 8 mm outside diameter (o/d) / 6 mm inside diameter (i/d)

ATTENTION

Use of non-original Gema spare parts

When using the spare parts from other manufacturers the explosion protection is no longer guaranteed. If any damage is caused by this use all guarantee claims become invalid!

- ▶ Only original Gema spare parts should be used!
-

OptiStar CG21 Gun control unit

	OptiStar CG21 gun control unit – complete, without item 4	1015 203
1	Front plate – complete, see corresponding spare parts list	
2	Enclosure	
3	Backplate – complete, see corresponding spare parts list	
4	Cover	1015 249

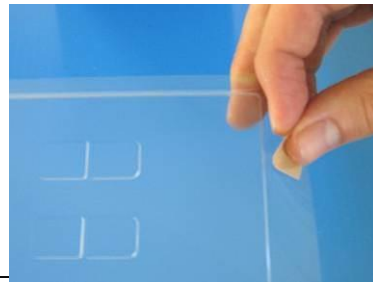

fig. 24

Front plate and power pack

	Front plate – complete (pos. 1-12)	1015 219
	Front plate with foil keyboard (pos. 5-8)	1015 218
1	OptiStar Mainboard – complete	1015 221
2	Spacer sleeve – Ø 3.1/6x15 mm	
3	PCB "Powerboard" – complete	1015 223
4	Spacer sleeve – Ø 3.2/6x7 mm	
5	Front frame – complete (incl. pos. 5.1)	1015 232
5.1	Screw	1007 019
6	Screw – M4x16 mm	1013 925
7	Front plate gasket	1015 236
8	Membrane keypad with carrier plate	1015 217
9	Spacer sleeve – Ø 3.6/7x5 mm	
10	Display	1015 220
11	Washer – Ø 3.2/7x0.5 mm	
12	Locknut – M3	
13	Power pack – 24 VDC	1009 849

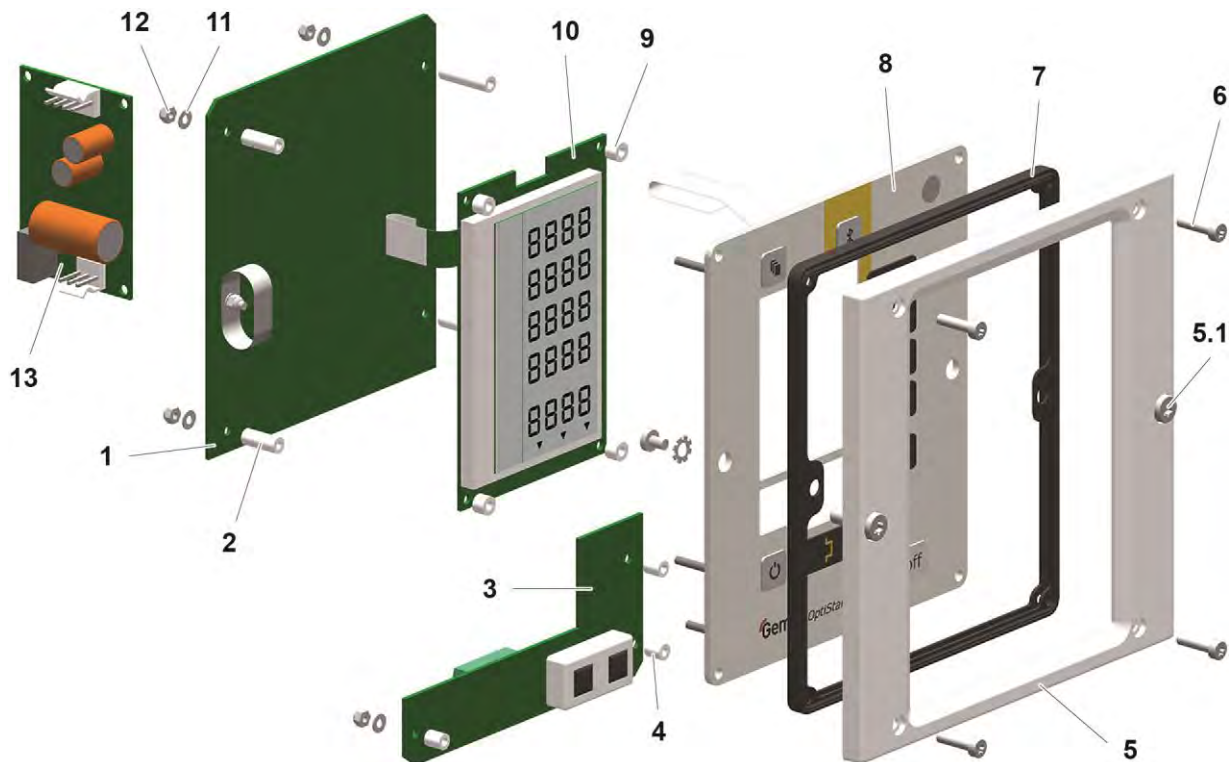

Fig. 25

Inside back plate

1	Back plate gasket	1015 198
2	Elbow joint – 1/8"-Ø 8 mm	251 372
3	T-piece – 1/4"- Ø 8 - Ø 8 mm	1008 040
4	Solenoid valve – Ø 8-Ø 8 mm, 24 VDC	1003 914
5	O-ring – Ø 12x1.5 mm, NBR70	261 416
6	Motor throttle – complete	1000 064
7	O-ring – Ø 8x4 mm, NBR70	1001 521
8	Fluidizing pad – 1/8"	237 264
9	Screw – M4x16 mm	1013 925
10	Plastic tube – Ø 8/6 mm	103 152*
11	Motor throttle – complete	1008 012

* Please indicate length

Inside back plate

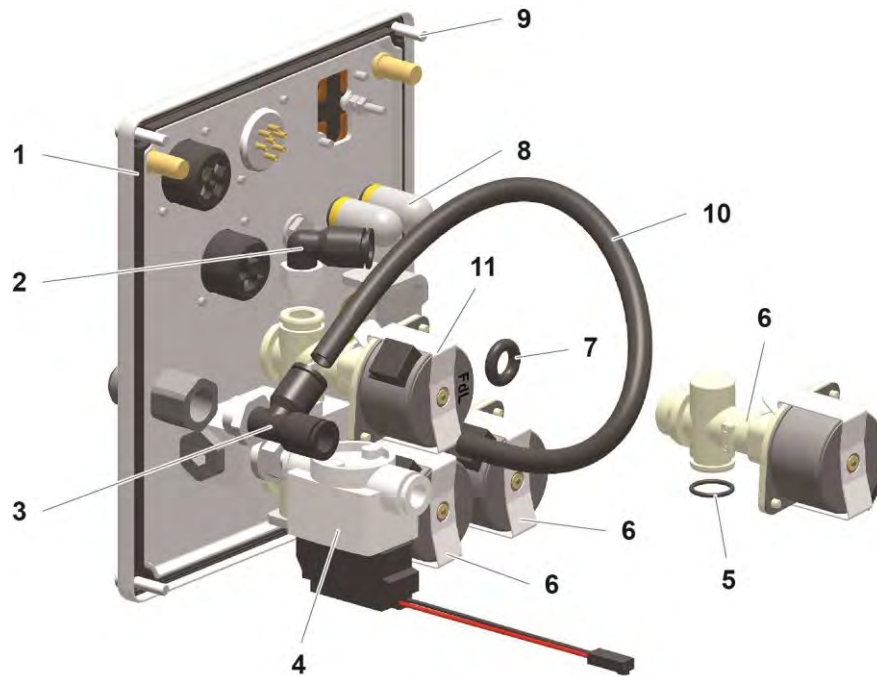

fig. 26: OptiStar CG21

Connecting material

1	Quick release connection – NW5, Ø 6 mm	200 840
1.1	Hose – Ø 6/4 mm	100 854*
2	Nut with kink protection – M12x1 mm, Ø 8 mm	201 316
2.1	Supplementary air hose – Ø 8/6 mm (black)	103 756*
2.2	Quick release coupling for supplementary air hose – NW5-Ø 8 mm	261 637
3	Nut with kink protection – M12x1 mm, Ø 8 mm	201 316
3.1	Conveying air hose – Ø 8/6 mm (red)	103 500*
3.2	Quick release coupling for conveying air hose – NW5-Ø 8 mm	261 645
4	Quick release connection – NW5-Ø 8 mm	203 181
4.1	Hose – Ø 8/6 mm	103 756*
5	Quick release connection – NW 5-Ø 6 mm	200 840
5.1	Hose – Ø 6/4 mm	100 854*
6	Vibrator cable (constituent part of vibrator)	
8	PowerClean module cable – 1 m (option)	1009 879
	PowerClean module cable – 15 m (option)	1009 880
9	Mains cable – CH	382 493
	Mains cable – Schuko	382 485
	Mains cable – USA	382 507
	Mains cable – GB	382 515
	Mains cable – AUS	382 523
	Mains cable – China	1000 993

* Please indicate length

Connecting material



fig. 27

Index

A

About these instructions.....	7
Assembly.....	29

B

Basic safety instructions.....	9
Bluetooth ID no.	37

C

Compressed air hoses / cables.....	21
Connectable guns	13
Connection	29
Connections	21

D

Decommissioning.....	53
Design and function	17
Dimensions	14
Disassembly of component groups.....	61
Disposal.....	61
Disposal regulations.....	61
Disuse for several days.....	53

E

E-App	25
Pairing.....	39
Electrical data.....	13
Environmental conditions.....	15

F

Fault clearance.....	57
Figure references in the text	8

G

Guidelines, European.....	12
---------------------------	----

I

Input keys and switches.....	19
Intended use	11

M

Maintenance.....	55
------------------	----

Maintenance during storage.....	54
---------------------------------	----

O

Operating elements	18
Displays.....	18
Input keys and switches.....	19
Operating modes	23
Operation	41
Overall view	17

P

PCC mode	24
Periodic checks	55
Pictograms.....	7
Pin assignment	22
Pneumatic data.....	14
Powder output (reference values)	14
PowerBoost Mode	24
Presentation of the contents.....	8
Preset mode	23
Product description.....	11
Product specific security regulations	9
Program mode	24

R

Rating plate.....	16
Repair work.....	55
Repairs	55

S

Safety.....	9
Safety symbols	7
Scope of delivery	23
Shutdown.....	53
Sound pressure level.....	16
Spare parts list.....	63
Standards, European.....	12
Start-up	31
Storage	53
Storage conditions	53

T

Typical characteristics	23
-------------------------------	----

